

USEFUL FOR HOLDING MOSTGM AUTOMATIC TRANSMISSIONS DURING REBUILDS

MOST DIMENSIONS AND MATERIALS ARE NON-CRITICAL

RECOMMEND **NOT** PAINTING THE FINISHED PRODUCT, SO NO PAINT CHIPS OFF INTO TRANSMISSION

I HAVE NOT FOUND ANY "HANDLE" NECESSARY

 Mr. WELLWOOD'S SHOP OF HORRORS www.gwellwood.com	PROJECT			
	TRANSMISSION STAND			
	TITLE			
	PLANS			
APPROVED	SIZE	CODE	DWG NO	REV
CHECKED	B			
DRAWN	Greg Wellwood	21/11/27	SCALE	WEIGHT
				SHEET 1/10

FITS MOST GM AUTOMATIC TRANSMISSIONS

FITS MOST ENGINE STANDS

PRECISION MESURMENT IS NOT CRITICAL;
KEEP IN MIND WHAT IT IS

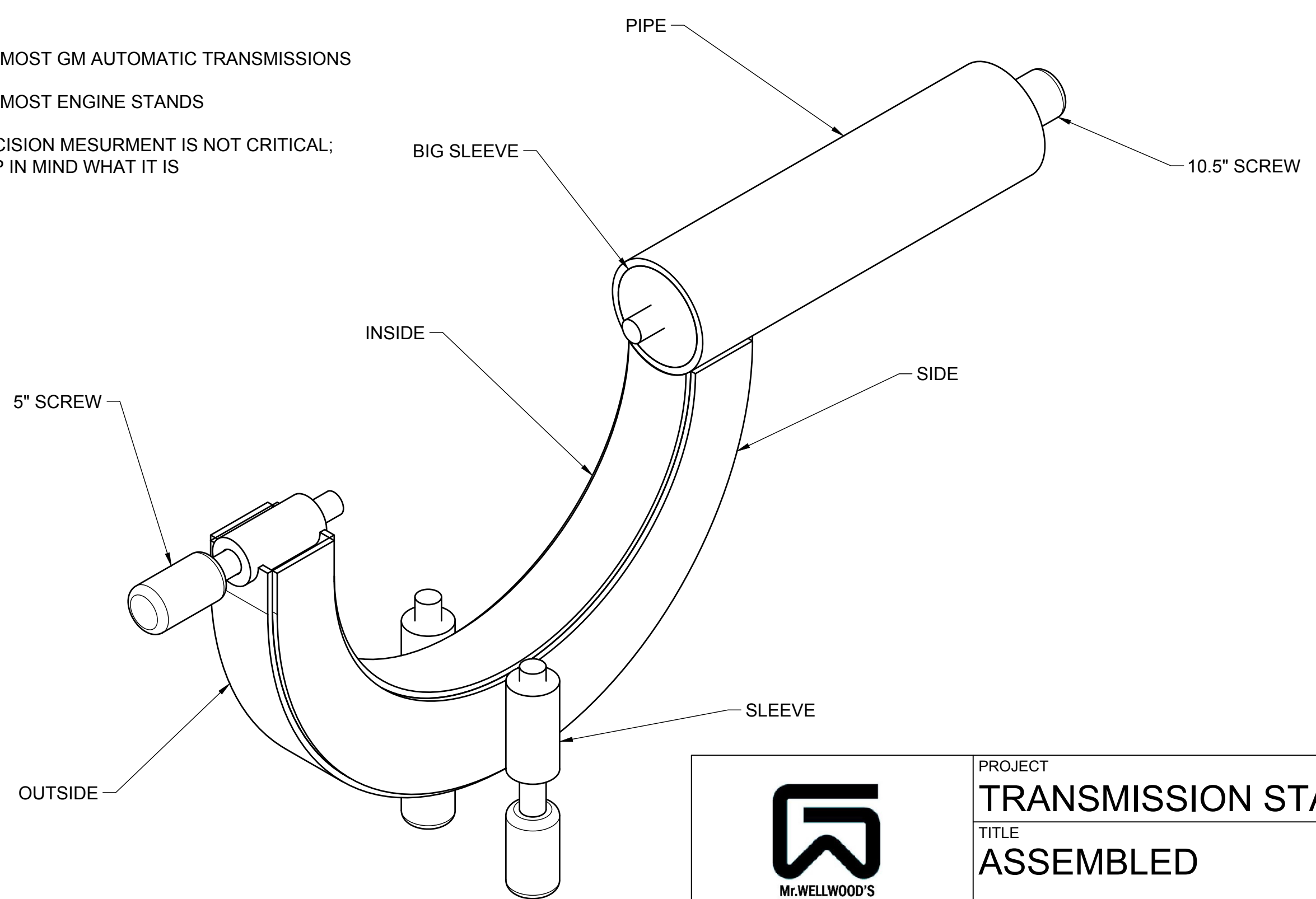

 Mr. WELLWOOD'S SHOP OF HORRORS www.gwellwood.com	PROJECT TRANSMISSION STAND			
	TITLE ASSEMBLED			
APPROVED	SIZE	CODE	DWG NO	REV
CHECKED	B			
DRAWN	Greg Wellwood	21/11/27	SCALE 1:4	WEIGHT
			SHEET 2/10	

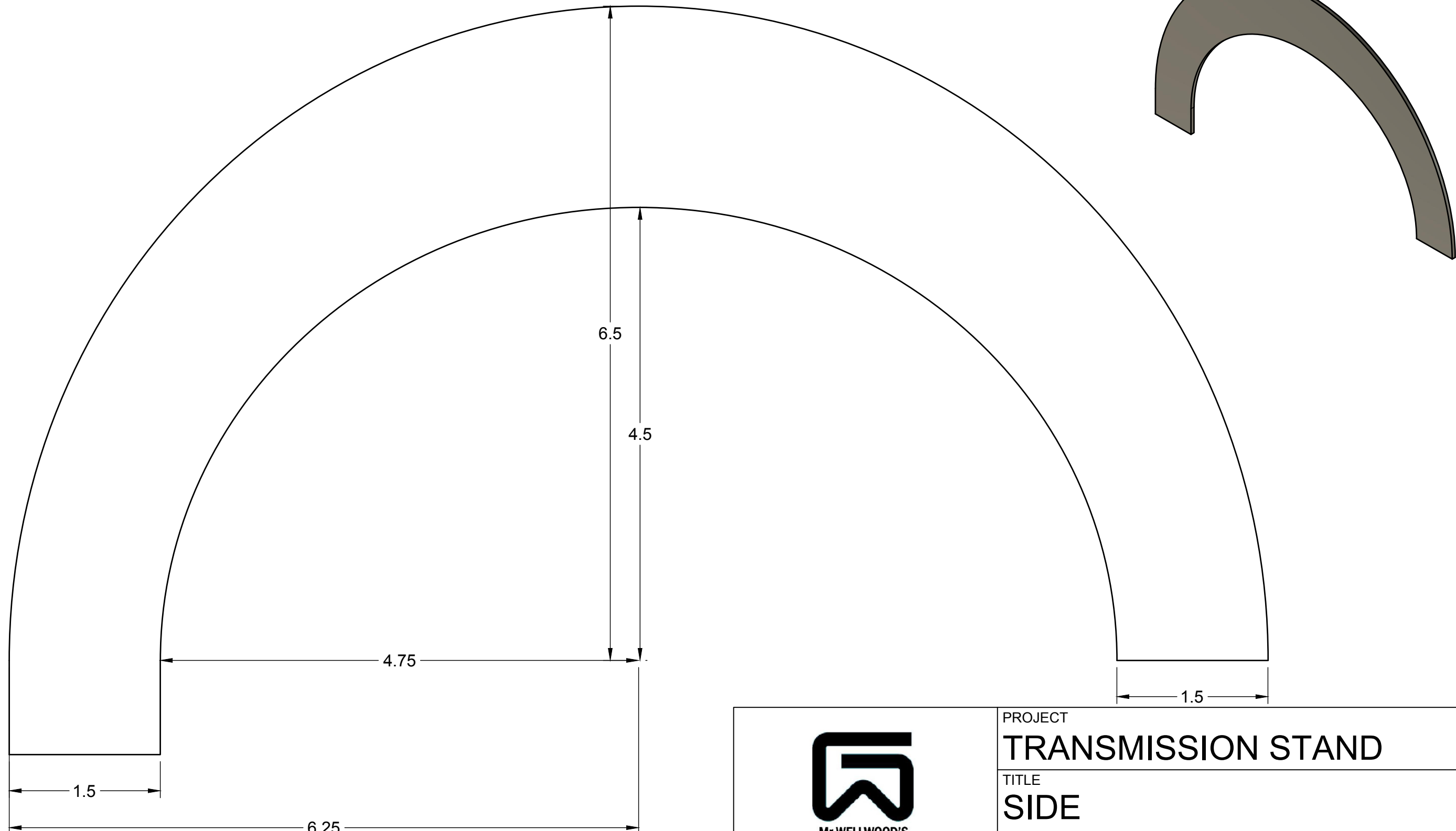

PRINTED on 11x17 PAPER, THIS PATTERN IS 1:1
 0.125" MILD STEEL SHEET
 (2) REQUIRED

 Mr. WELLWOOD'S SHOP OF HORRORS www.gwellwood.com	PROJECT			
	TRANSMISSION STAND			
TITLE				
SIDE				
APPROVED	SIZE	CODE	DWG NO	REV
CHECKED	B			
DRAWN	Greg Wellwood	21/11/27	SCALE 1:1	WEIGHT
			SHEET 3/10	

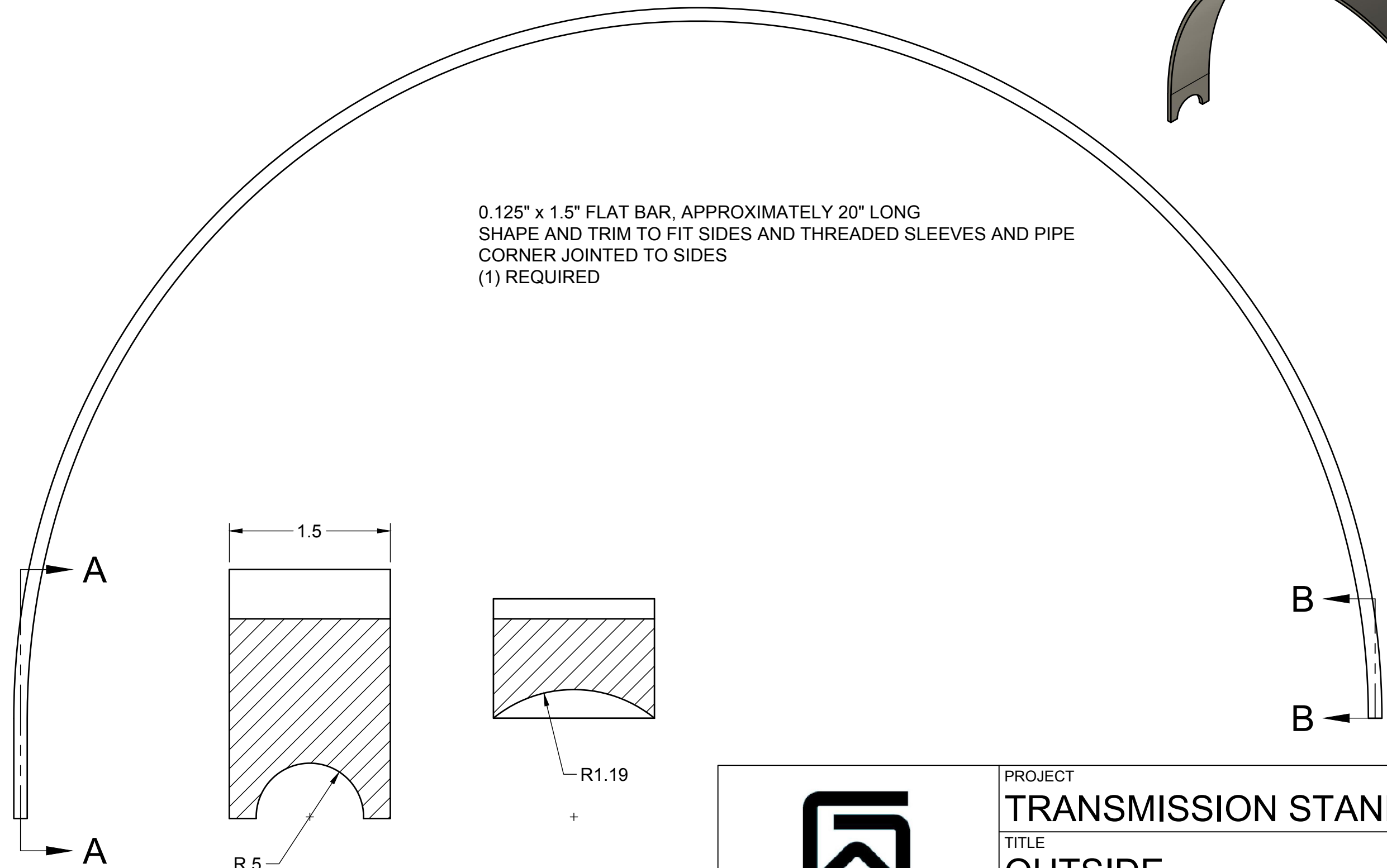

0.125" x 1.5" FLAT BAR, APPROXIMATELY 20" LONG
 SHAPE AND TRIM TO FIT SIDES AND THREADED SLEEVES AND PIPE
 CORNER JOINTED TO SIDES
 (1) REQUIRED

SECTION A-A
 SCALE 1:1

SECTION B-B
 SCALE 1:1

 Mr. WELLWOOD'S SHOP OF HORRORS www.gwellwood.com	PROJECT			
	TRANSMISSION STAND			
TITLE				
OUTSIDE				
APPROVED	SIZE	CODE	DWG NO	REV
CHECKED	B			
DRAWN	Greg Wellwood	21/11/27	SCALE 1:1	WEIGHT
			SHEET 4/10	

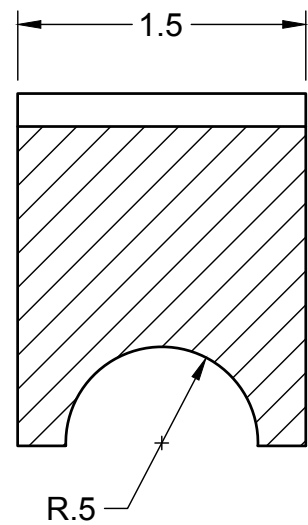
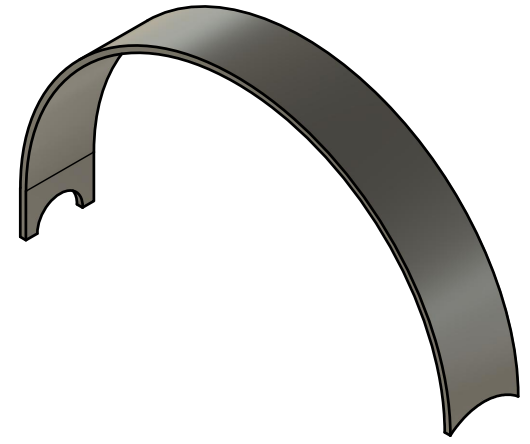
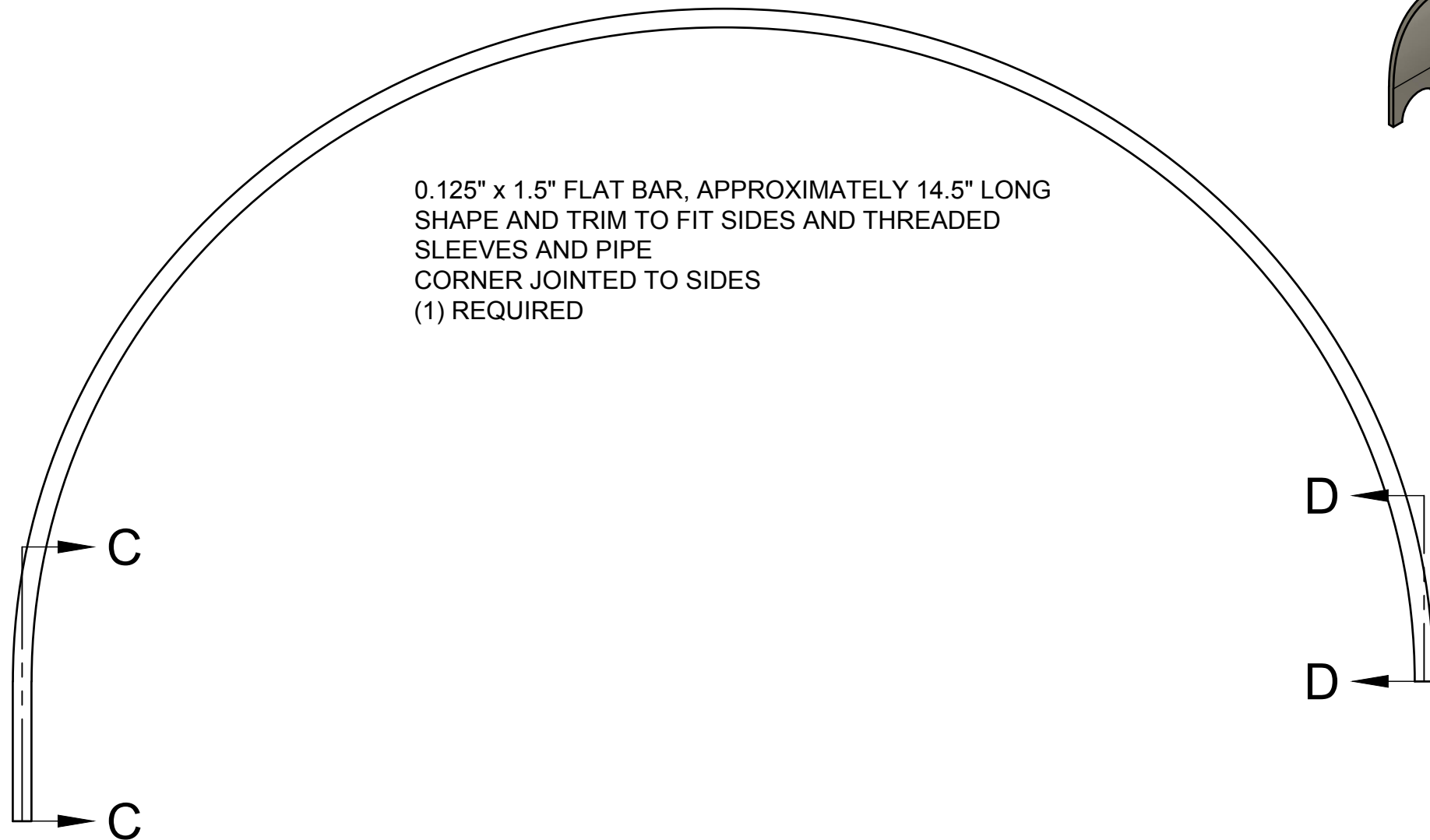

SECTION C-C
 SCALE 1:1

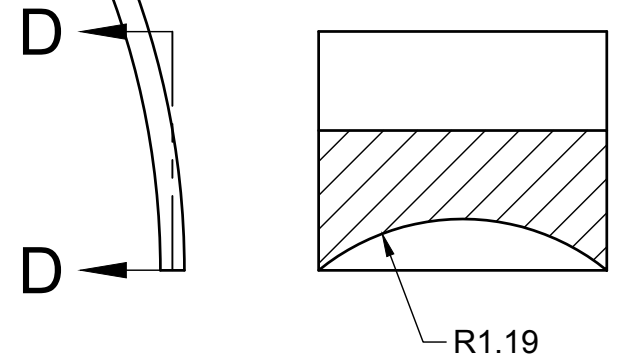

SECTION D-D
 SCALE 1:1

 Mr. WELLWOOD'S SHOP OF HORRORS www.gwellwood.com	PROJECT			
	TRANSMISSION STAND			
TITLE				
INSIDE				
APPROVED	SIZE	CODE	DWG NO	REV
CHECKED	B			
DRAWN	Greg Wellwood	21/11/27	SCALE 1:1	WEIGHT
				SHEET 5/10

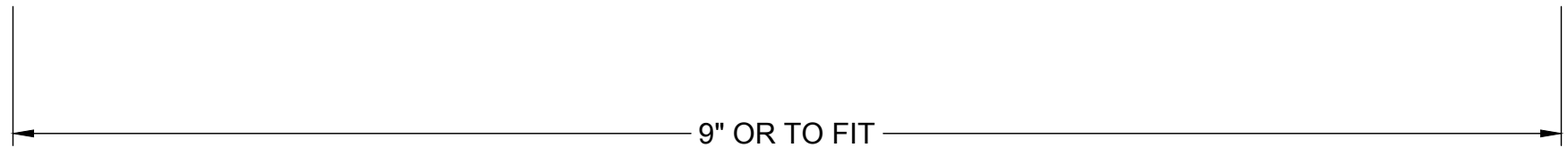
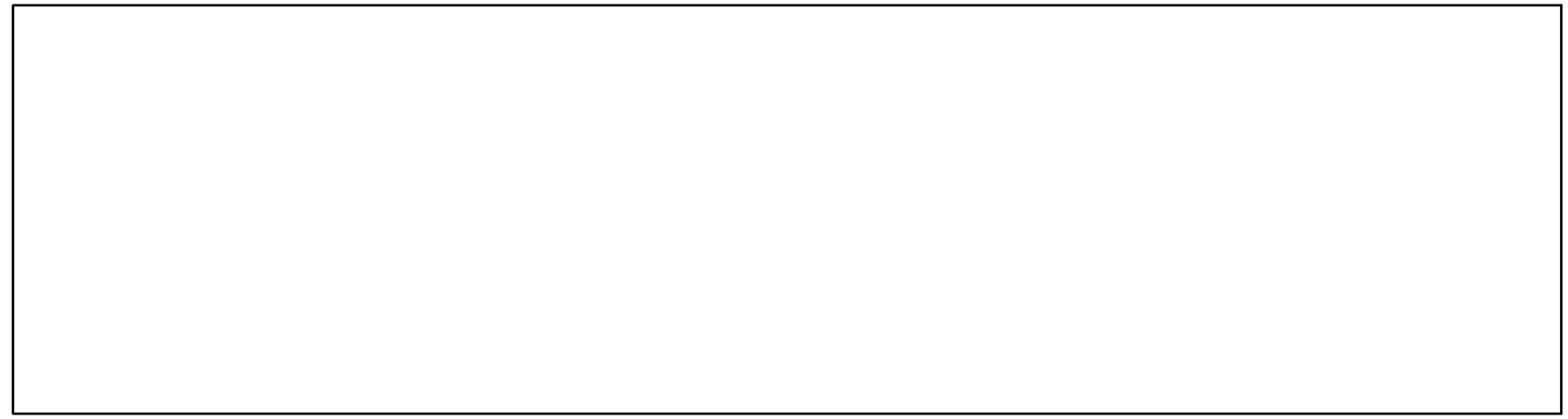
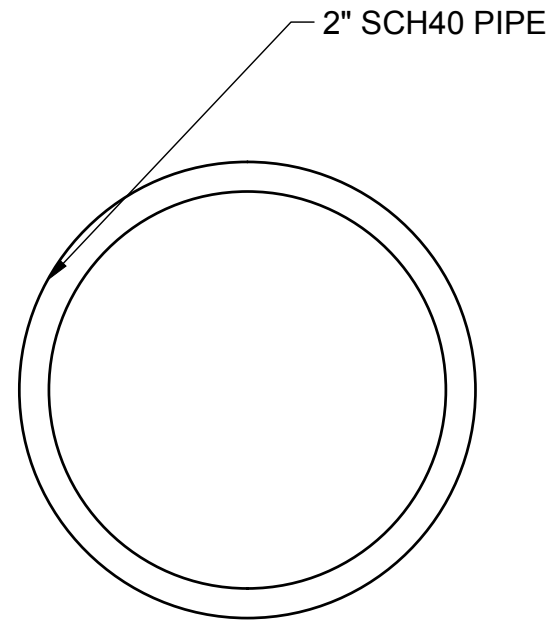
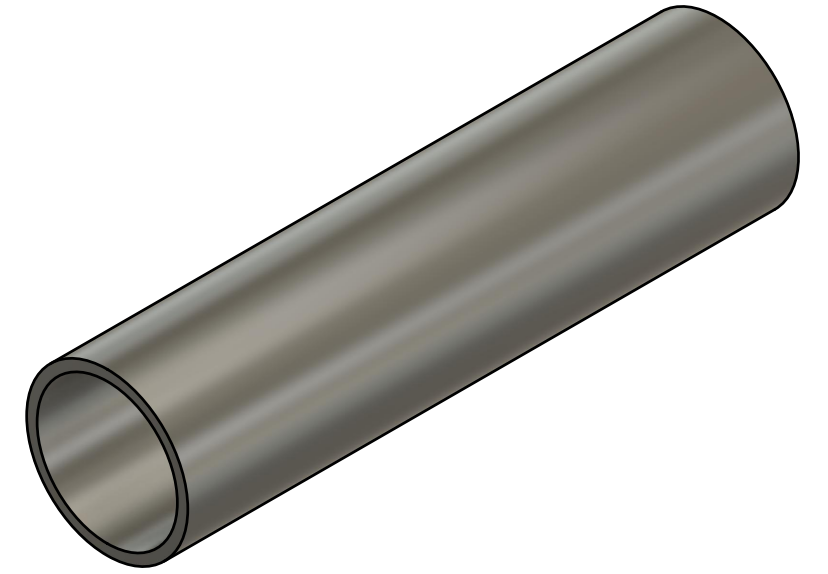

PROJECT
TRANSMISSION STAND

TITLE
PIPE

APPROVED	SIZE	CODE	DWG NO	REV
CHECKED	B			
DRAWN	Greg Wellwood	21/11/27	SCALE 1:1	WEIGHT
			SHEET 6/10	

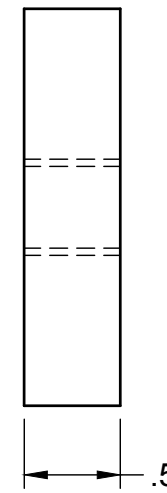
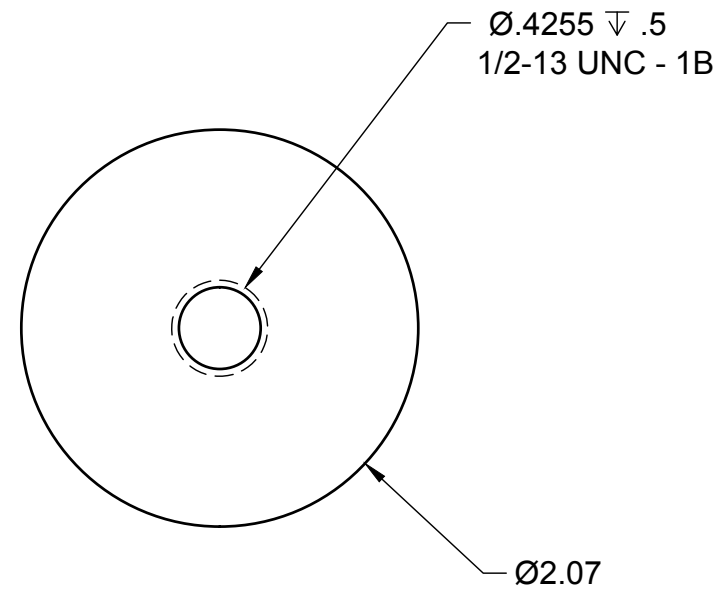
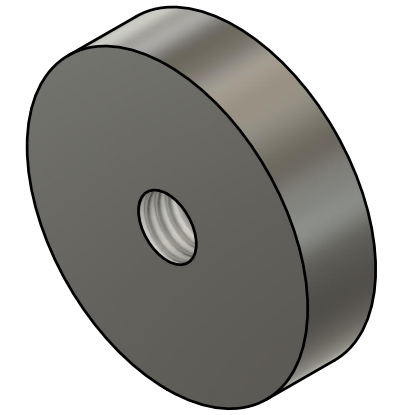

MILD STEEL
(1) REQUIRED



Mr. WELLWOOD'S
SHOP OF HORRORS
www.gwellwood.com

PROJECT

TRANSMISSION STAND

TITLE

BIG SLEEVE

APPROVED	SIZE	CODE	DWG NO	REV
CHECKED	B			
DRAWN	Greg Wellwood	21/11/27	SCALE 1:1	WEIGHT
				SHEET 7/10

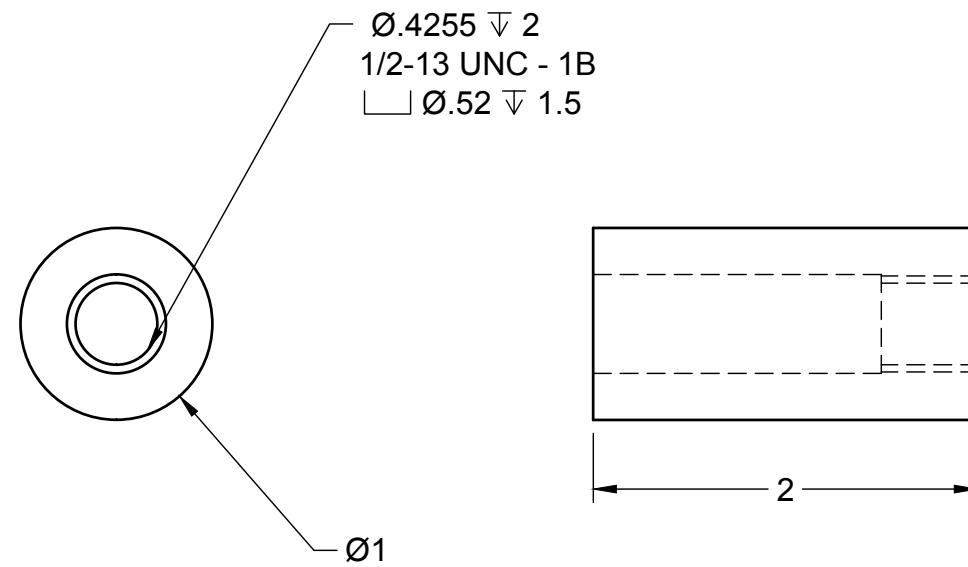
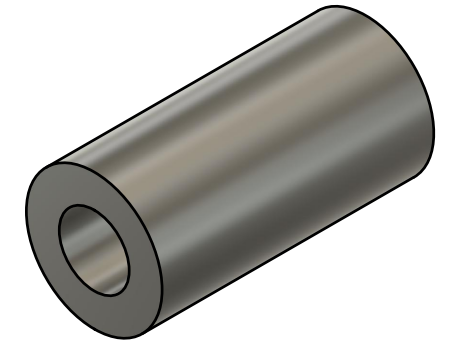

MILD STEEL
(3) REQUIRED

CAN ALSO JUST USE COUPLING NUTS

I HAVE FOUND DIAMETERS GREATER THAN 1" ARE A PROBLEM WITH 4L80E (POSSIBLY OTHERS)



Mr. WELLWOOD'S
SHOP OF HORRORS
www.gwellwood.com

PROJECT

TRANSMISSION STAND

TITLE

SLEEVE

APPROVED

CHECKED

DRAWN

Greg Wellwood 21/11/27

SIZE

B

SCALE 1:1

CODE

DWG NO

WEIGHT

REV

SHEET 8/10

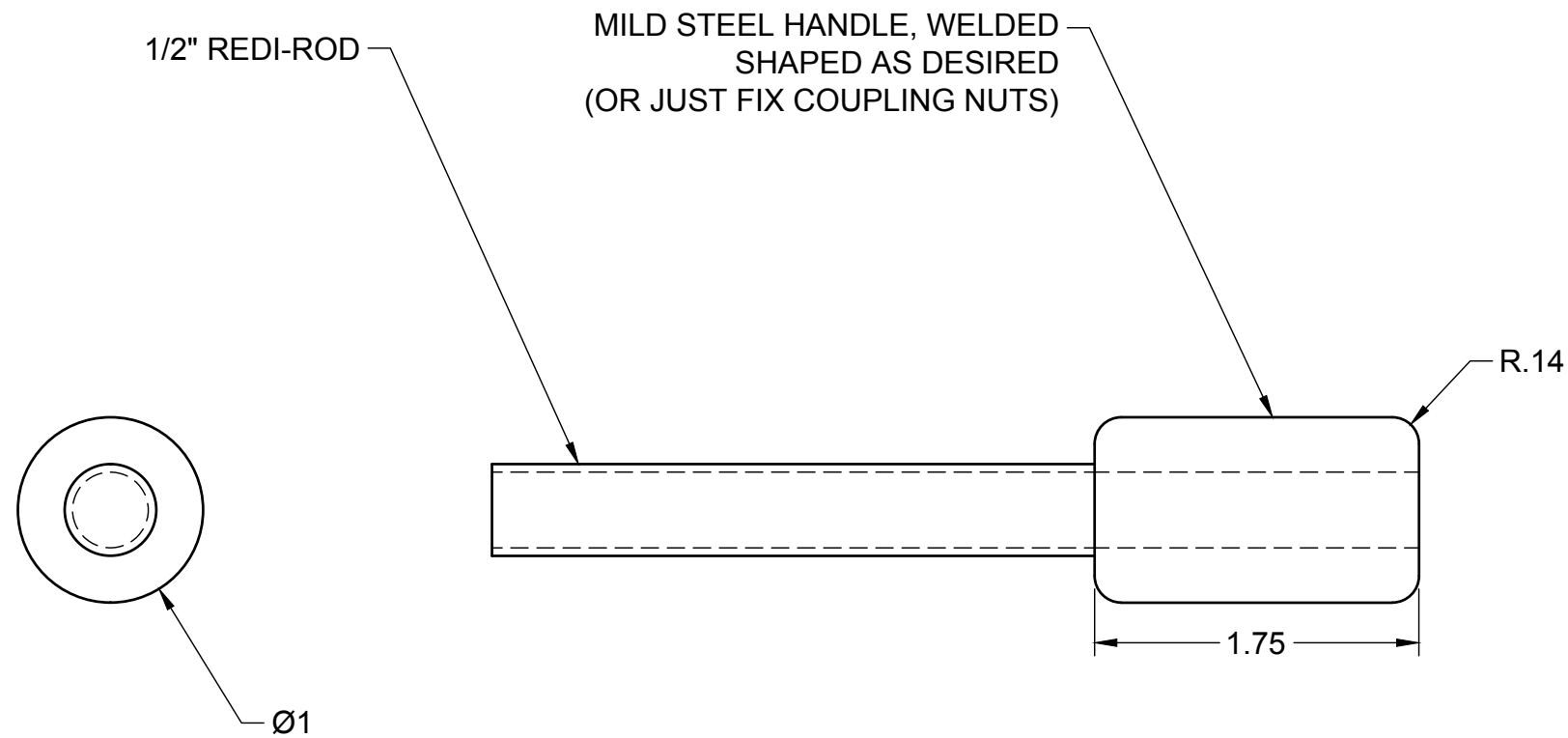

MILD STEEL HANDLE, WELDED
SHAPED AS DESIRED
(OR JUST FIX COUPLING NUTS)

RECOMMEND REDI-ROD

- (3) REQUIRED AT ABOUT 5" (MAKE TO FIT)
- (1) REQUIRED AT ABOUT 10.5" (MAKE TO FIT)

CAN USE COUPLING NUTS JAMMED TO A NYLOC NUT FOR EASY HANDLES

 Mr. WELLWOOD'S SHOP OF HORRORS www.gwellwood.com	PROJECT			
	TRANSMISSION STAND			
TITLE				
SCREW				
APPROVED	SIZE	CODE	DWG NO	REV
CHECKED	B			
DRAWN	Greg Wellwood	21/11/27	SCALE 1:1	WEIGHT
			SHEET 9/10	

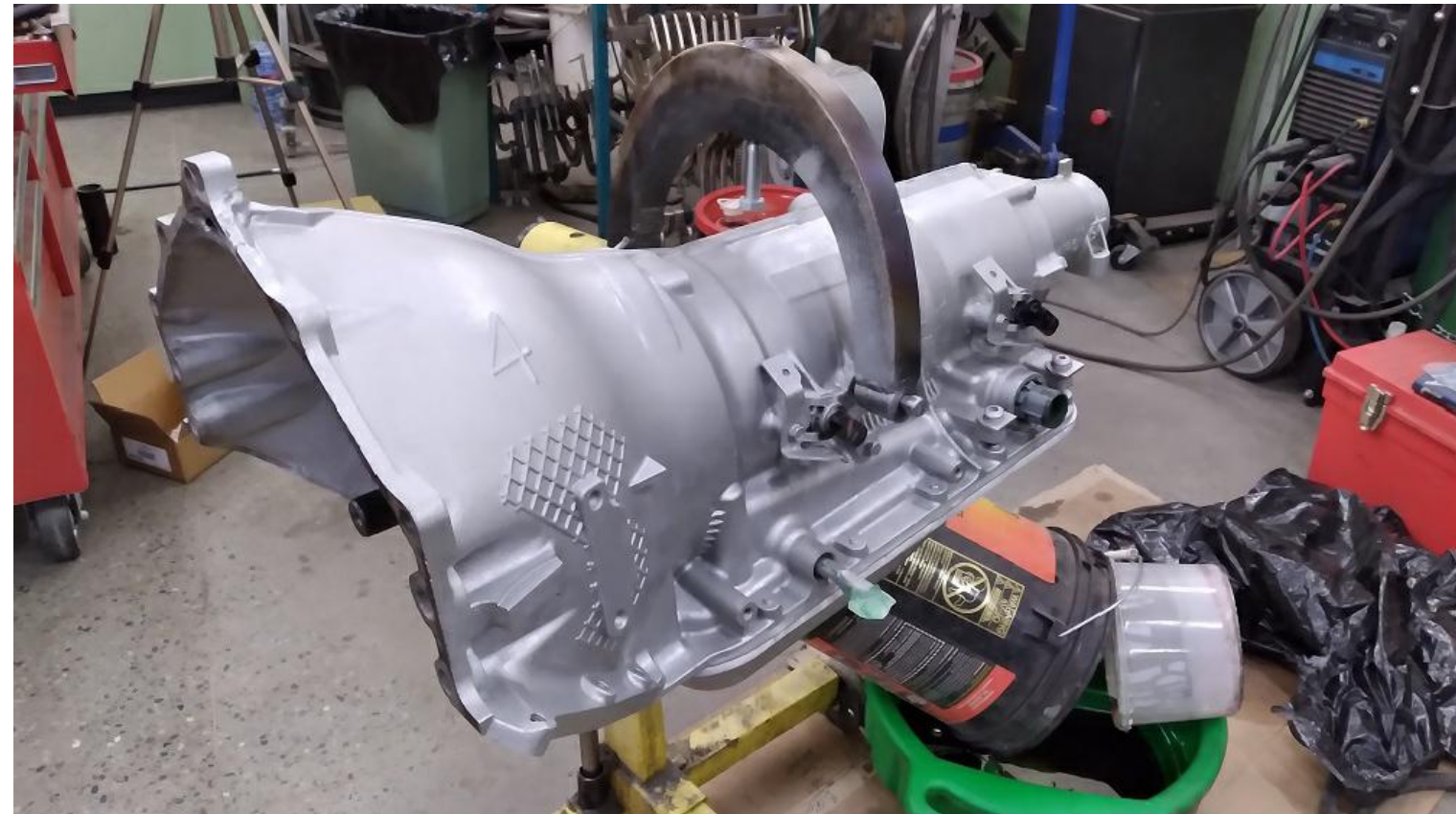
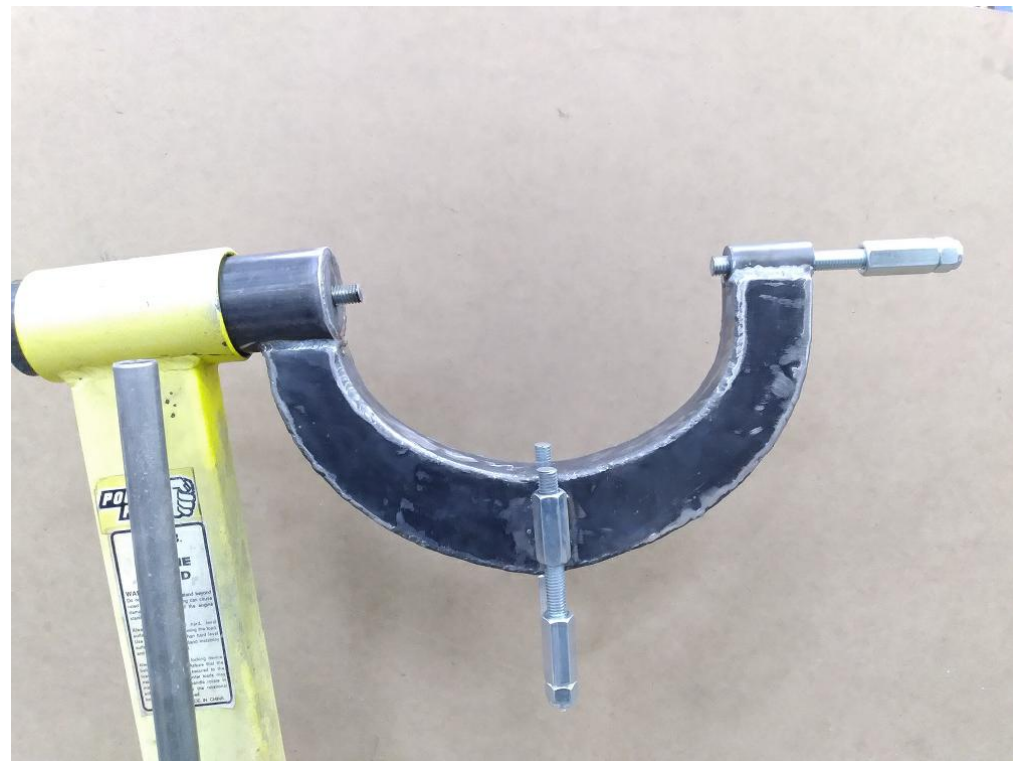

A PREVIOUS DESIGN - HORSESHOE WAS TOO DEEP

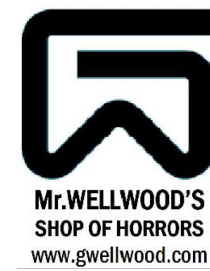

PROJECT
TRANSMISSION STAND

TITLE
EXAMPLES

APPROVED	SIZE	CODE	DWG NO	REV
CHECKED	B			
DRAWN	Greg Wellwood	21/11/27	SCALE	WEIGHT
				SHEET 10/10